

Shrinkwrappers

\* OUTPUT

\*\* DIMENSIONS

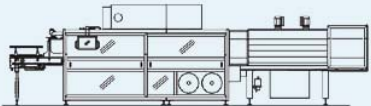
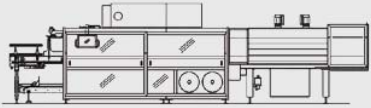
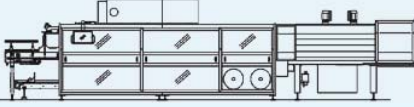

LSK SERIES	LSK 20 F	FILM ONLY	20 PPM		8570 x 1620 x 2520 mm
	LSK 35 F		35 PPM		9070 x 1620 x 2520 mm
	LSK 20 P	PAD + FILM	20 PPM		8570 x 1620 x 2520 mm
	LSK 35 P		35 PPM		9070 x 1620 x 2520 mm
	LSK 20 T	TRAY ONLY	20 PPM		9865 x 1620 x 2520 mm
	LSK 35 T		TRAY + FILM		35 PPM

Pag. 4-5

Shrinkwrappers

\* OUTPUT

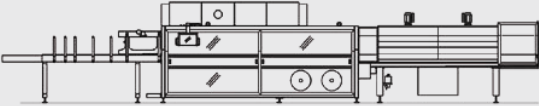
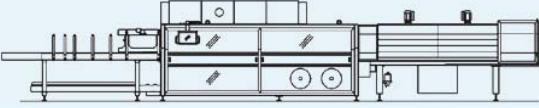
\*\* DIMENSIONS

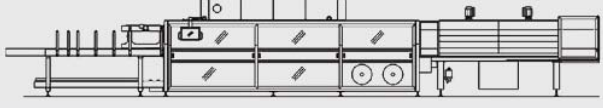
SK SERIES	SK 450 F	FILM ONLY	45 PPM		14900 x 1600 x 2500 mm
	SK 600 F		60 PPM		17400 x 1600 x 2500 mm
	SK 800 F		80 PPM		18400 x 1600 x 2500 mm
	SK 452 F		80 PPM		17400 x 1800 x 2500 mm
	SK 602 F		100 PPM		18400 x 1800 x 2500 mm
	SK 802 F		140 PPM		19400 x 1800 x 2500 mm
	SK 800 F	FILM ONLY Cans and/or small containers	120 PPM		18400x1600x2500 / 19400x1800x2500 mm
	SK 800 F / SK 802 F - Packs on 2 lanes		240 PPM		18400x1600x2500 / 19400x1800x2500 mm
	SK 800 F / SK 802 F - Packs on 3 lanes		360 PPM		18400x1600x2500 / 19400x1800x2500 mm
	SK 450 P	PAD + FILM	45 PPM		14900 x 1600 x 2500 mm
	SK 600 P		60 PPM		17400 x 1600 x 2500 mm
	SK 800 P		80 PPM		18400 x 1600 x 2500 mm
	SK 452 P		80 PPM		17400 x 1800 x 2500 mm
	SK 602 P		100 PPM		18400 x 1800 x 2500 mm
	SK 802 P		140 PPM		19400 x 1800 x 2500 mm
	SK 450 T	TRAY ONLY	45 PPM		16390 x 1600 x 2500 mm
SK 600 T	60 PPM		19960 x 1600 x 2500 mm		
<b>SK 800 T</b>	<b>80 PPM</b>		<b>20960 x 1600 x 2500 mm</b>		
SK 452 T	80 PPM		20040 x 1800 x 2500 mm		
SK 602 T	100 PPM		20960 x 1800 x 2500 mm		
SK 802 T	140 PPM		21960 x 1800 x 2500 mm		

Pag. 6-7

\* Maximum output in packs per minute referred to 3x2 packs of 1.5 L stable containers.

\*\* Length x width x height.

Data mentioned here are subject to changes without notice.

# SK Series



Medium-high speed  
shrink wrappers



## Models up to 360 PPM

### SINGLE LANE

SK 450 F	SK 450 P	SK 450 T
SK 600 F	SK 600 P	SK 600 T
SK 800 F	SK 800 P	SK 800 T

### DOUBLE LANE

SK 452 F	SK 452 P	SK 452 T
SK 602 F	SK 602 P	SK 602 T
SK 802 F	SK 802 P	SK 802 T

The SK series is composed of automatic machines for packing plastic, metal or glass containers. Depending on the model chosen, they can make packs in film only, cardboard pad + film, tray only, cardboard tray + film. The SK series can achieve an output up to 360 packs per minute, depending on the machine model and on the product to be packaged. The pack collations can vary according to the container shape and size. In general, the most frequently requested collations are: 2x2, 3x2, 4x3 and 6x4. All SK models are equipped with an electronic grouping device and are available with single or double lane, according to the customer's exigencies. The change-over is automatic.

## The packaging process

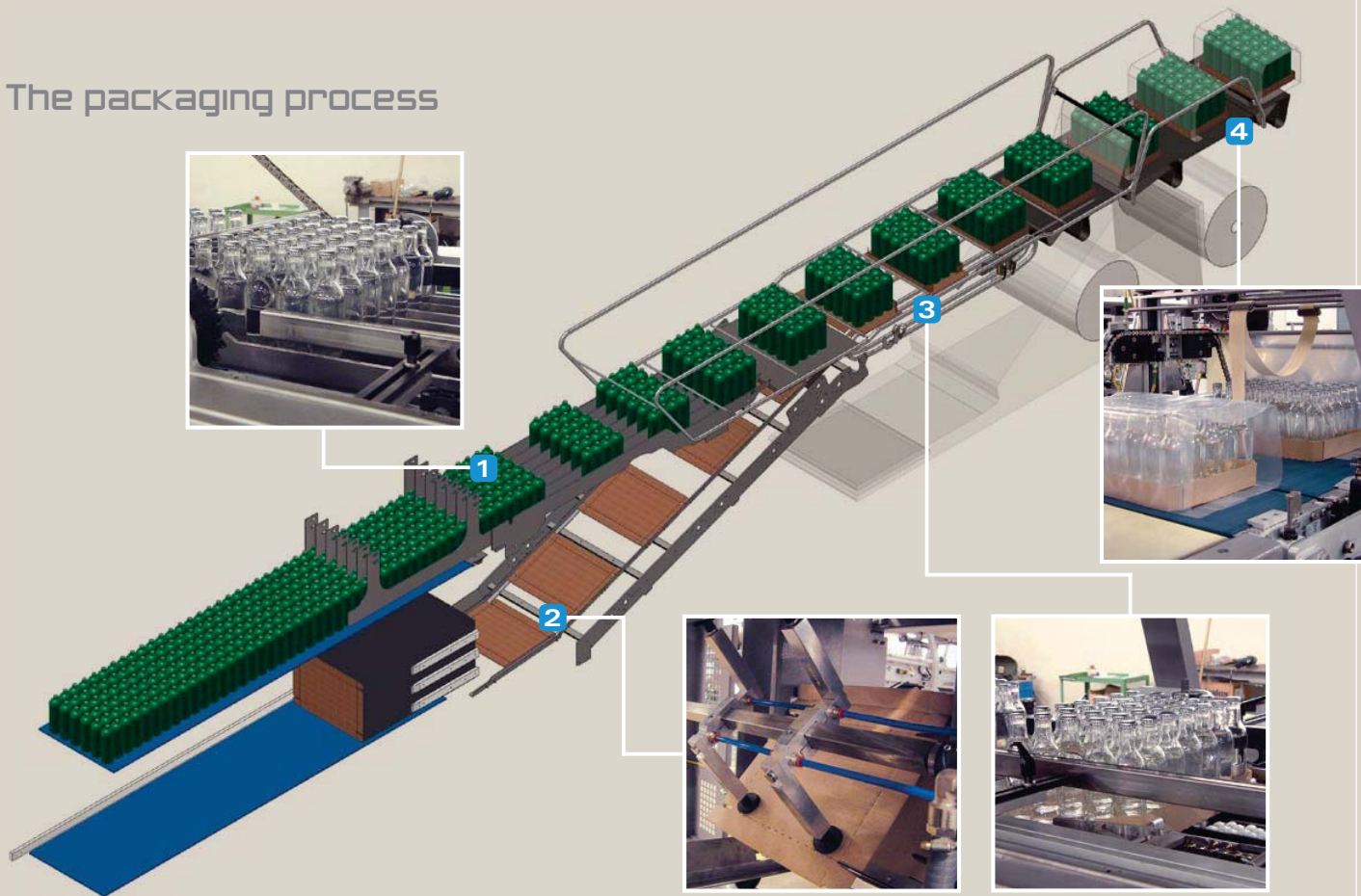

1. In the machine infeed zone, a group of guides accurately lines up the loose containers carried by a conveyor belt featuring low-friction chains made of thermoplastic material. In the pack formation zone, the containers are clustered in the required format through electronically synchronized fingers and dividing bars, operating in continuous motion.

2. In P and T models, a corrugated cardboard pad or blank is picked from the blanks magazine by a rotary picker composed of two groups of vacuum suckers. The pad or the blank moves along the blank climb and places itself underneath the group of products in transit with the long side leading.

3. In the trayformer, special mechanical devices fold the blank's front and rear flaps. The side flaps are sprayed with hot melt glue and then folded, thus forming the tray.

4. The unwinding of the film reels, placed in the lower part of the machine, is controlled by a brushless motor, which ensures the film constant tension. Before the pack enters the shrinking tunnel, the film is wrapped around the container batch and overlapped at the base of the pack.

## Automatic and precise film cut

In all SK models, the film reel group is electronically controlled by a brushless motor, which ensures the film constant and perfect tension, as well as more precision during the cutting operation. As a consequence, the pack quality is definitely improved.

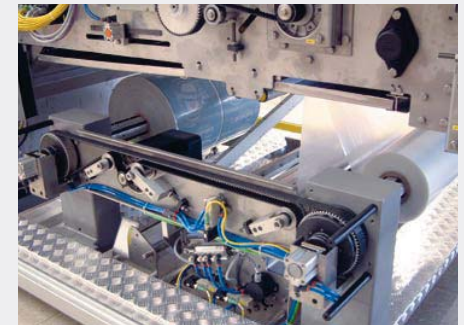

## Available accessories

TLESPACK	TS	EASY OPEN	PID SBP
x	x	x	-

(Pag. 16 - 17 - 18)

# Automation

SMI exclusively manufactures third generation (GEN3) packaging machines; they feature modular design, operating flexibility and high performances, thanks to the fully automatic processes, the electronically controlled drive shafts and the wiring by field bus.



The hardware and software components are open and modular, complying with the most important international rules (CE, UL) and relying upon consolidated standards of the industrial field and of the packaging sector: OMAC guidelines, SERCOS, PROFIBUS, IEC61131, OPC, Industrial PC. As a result, SMI machines can guarantee easy integration with the other machines in line, user friendly technology and safeguard of the investment value.

The machine hardware includes: MARTS (process controller), POSYC (man-machine interface), COSMOS (digital servodriver for brushless motors), dGATE and aGATE (remote IP65 I/O digital/analogic modules). The MARTS is a PAC (Programmable Automation Controller), based on an industrial PC, which can be programmed in IEC61131 languages. The COSMOS servodrivers and the dGATE/aGATE I/O modules are connected to the PAC via SERCOS.

The POSYC is a control panel with IP65 touch screen and is based on a fanless PC with solid state drive.



## SMI automation and control solutions ensure:

- High outputs, with excellent quality levels.
- Constant maintenance of the control parameters.
- Reduced noise of the machines.
- Direct control of the conveyors connected to the machine, without additional plc.
- User's friendly technology.
- POSYC automatic warning of maintenance needed.
- Quick changeover.
- Programmable machine pitch and drive shafts movement.
- On-line manuals on POSYC.
- Machine performance monitoring and down-times analysis (Pareto diagram).
- OPC or MODBUS/TPC connection for production data collection.
- Teleassistance over the phone or through the Internet.
- Easy storage of the installation parameters.
- Easy updating.
- POSYC interchangeability with compatible Panel PCs (SIEMENS, ALLEN BRADLEY).
- COSMOS interchangeability with compatible SERCOS PACK PROFILE servodrivers (ALLEN BRADLEY).

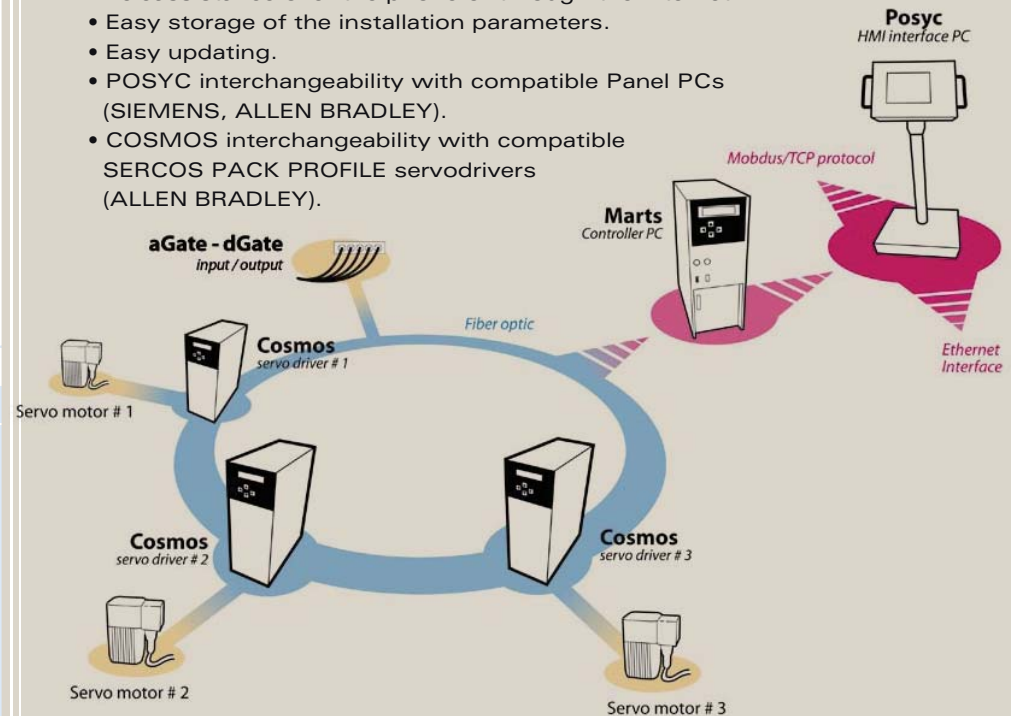

# Changeover



SMI packers are the ideal solution for the packaging of a wide range of products in countless pack collations.

Thanks to the very quick change-over time, it is very easy to change the format and immediately re-start the production. The operating parameters of each pack are stored in the POSYC control panel, so that the operator can select the required format directly on the touch screen. The mechanical adjustments of the machine sections might require the operator's manual intervention, depending on the machine model and on the product to be handled.

For the models with manual change-over, the operator can easily arrange the machine for the packaging of the new product collation, by means of counting devices and hand-cranks for the guides adjustment.

For the models with automatic change-over, the machine is electronically arranged for the packaging of the new format by means of brushless motors; in most cases, no tools or operator's intervention are needed. Thus, change-over operations simply consist in selecting the new format from the POSYC control panel.

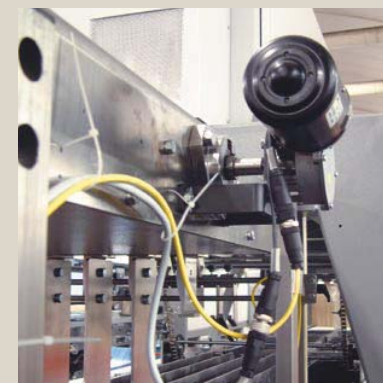

In order to make the shift from a small pack to a large pack or vice versa easier, SMI packers are set to control up to three different machine pitches, identified by coloured position indicators installed on the chains.

## Technical features

	LSK	SK	TF	MP	WP	CM
Machine bearing frame made of sand-blasted and powder-painted steel	X	X	X	X	X	X
Standardized modules assembly	X	X	X	X	X	X
Safety doors with aluminium frame and transparent protections made of shockproof polycarbonate, which allow an easy access to all parts of the machine and a broad visibility of the packaging process as a whole	X	X	X	X	X	X
Absence of motoreducers	X	X	X	X	X	X
Lifetime lubricated bearings	X	X	X	X	X	X
Infeed conveyour belt featuring low-friction thermoplastic material chains	X	X	X	X	X	X
Cardboard magazine situated beneath the infeed conveyour, adjustable according to the blank size	X	X	X		X	X
Cardboard magazine situated above the infeed conveyour, adjustable according to the blank size				X		
Alternate motion cardboard blank picker, equipped with suckers	X					
Continuous motion rotary cardboard blank picker, equipped with suckers		X	X	X		
Cardboard blank picker with rubberized chains					X	X
Film reel unwinding electronically controlled by brushless motors		X				X
Film cutting system with blade rotation	X	X				X
Automatic centring system for printed film provided with marks		X				X
Continuous motion product grouping device, with electronically synchronized fingers made of plastic material		X	X	X	X	X
Brush antistatic bars with carbon fibre	X	X				X
Heat-shrinking tunnel with centralized lubrication	X	X				X
Tunnel conveyour belt equipped with fibreglass bars	X	X				X
Tunnel automatic cleansing system		X				X
Machine electrical cabinet with air conditioner	X	X	X	X	X	X
Heat-shrinking tunnel with forced air ventilation	X	X				X
POSYC control panel mounted man-high and running the whole length of the machine	X	X	X	X	X	X
Power supply: from 380 to 480V (±5% max.) 50/60 Hz 3PH + PE	X	X	X	X	X	X
Power supply equal to 230 or 575V: with autotransformer	X	X	X	X	X	X