

description

The FA-55 is an automatic, turntable style wrapping machine designed for operatorless operation as it utilizes pallet loads for shipment or storage. The system can be integrated into an existing conveyor line or loaded and unloaded via lift truck. This light to medium duty automatic system is appropriate for use in a wide variety of applications.

operation

- 1) Load brought (or conveyed) to infeed conveyor
- 2) Load automatically conveyed to wrap zone
- 3) Automatic wrap cycle begins
- 4) After cycle, film tail is cut and wiped to load
- 5) Load automatically conveyed to exit conveyor

• FA-55 features

- Automatic operation saves labor costs, improves efficiency and package appearance
- Rugged 100% structural steel construction for years of reliable operation
- High performance film delivery system yields 245% prestretch (standard)
- Handles 48"x48" (max) loads weighing up to 4,000 pounds (standard)
- Automatically adjusts for various load heights (up to 72" maximum)
- 14 RPM maximum turntable rotation for rated throughput of 45 loads/hour
- State-of-the-art Allen Bradley PLC Controller
- 25" precision ring bearing turntable support / ANSI chain & sprocket drive
- Non-proprietary replacement parts can be purchased locally or from dealer
- Self-threading Insta-Thread™ carriage makes loading film fast, safe and easy
- Turntable has AC variable frequency drive for responsive speed control and long motor life

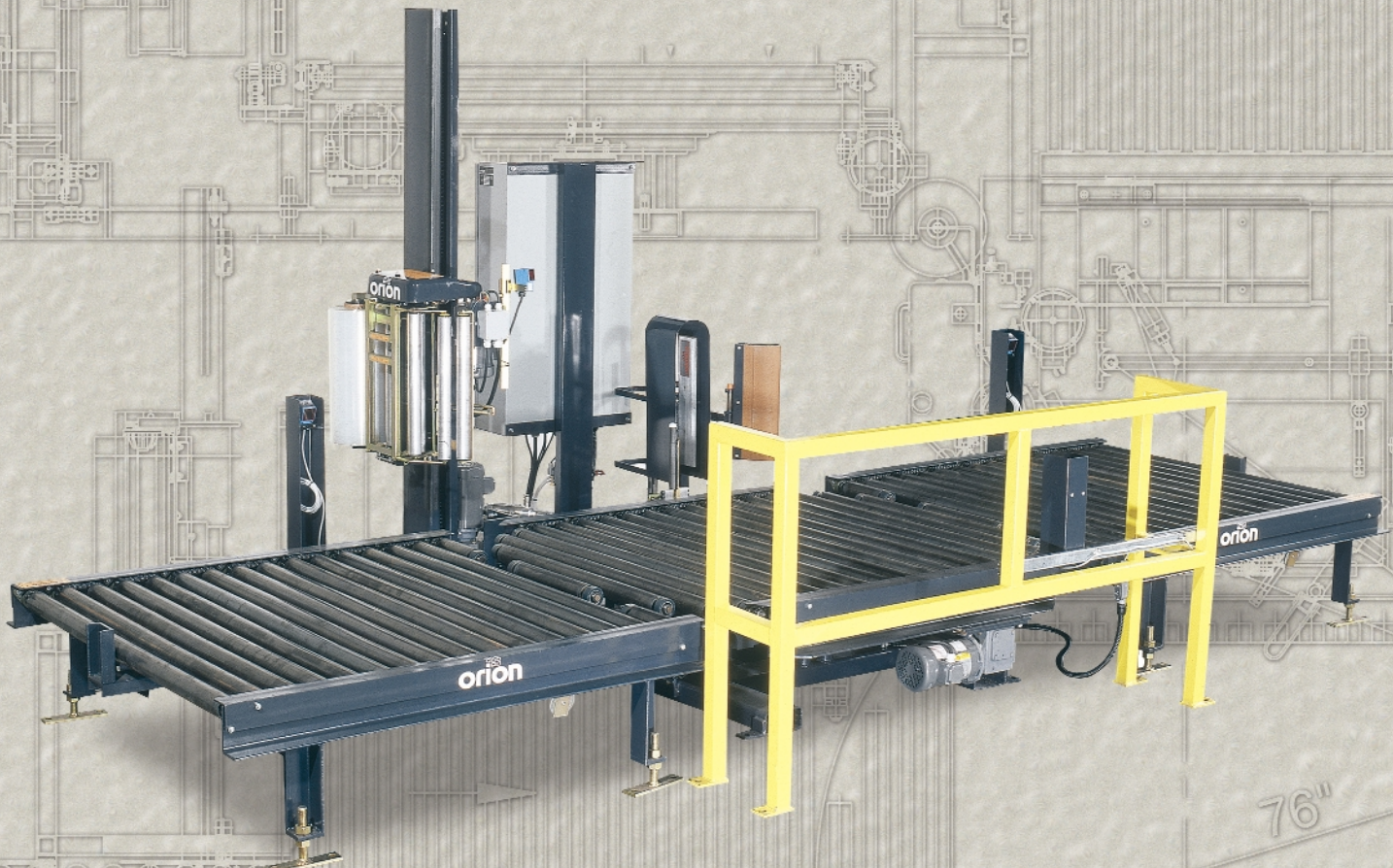

FA-55 specifications

Machine Performance

Rotation speed Variable to 14 RPM

Film Delivery System

Prestretch ratio 245% standard rate
(100% to 425% options)

Threading method Insta-Thread

Corner compensation Electronic non-wearing

Load Specifications

Maximum load weight 4,000 pounds

Maximum load size 48"W x 48"L x 72" H

Minimum load size 30"W x 30"L x 26" H

Utilities

208 / 3 / 60 15 amp

3 CFM air @ 80 PSI

Structural Design

100% Structural steel used throughout

Ergonomic chassis layout for ease of use

Structural steel tube mast

Side facing carriage for easy roll changes

Forklift portable base design

Warranty

3/5 Year limited

Estimated Shipping Weight

5,500 pounds

FA-55 dimensions

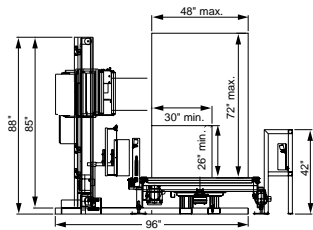
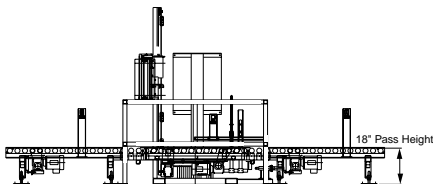
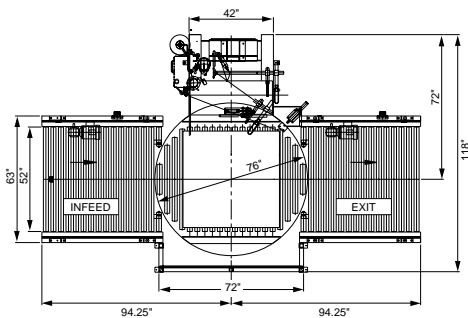

Heavy-duty conveyors

Orion conveyors have a rock-solid reputation for long term durability and reliability. From their structural steel frames to their heavy duty bearings, these conveyors are built to last!

- 100% Orion manufactured using 100% structural steel for maximum strength & durability
- 5' Infeed & 5' Exit conveyor included
- Fully automatic sequencing logic
- 4,000 pound maximum load weight capacity
- 2.5" diameter rollers on 3.75" centers
- 18" Height to Top of Rollers
- 52" Effective conveyor width
- All rollers driven via heavy duty ANSI loop to loop
- 40 fpm standard speed
- AC fixed speed drive



Conveyor rollers are supported by full length solid steel axles and welded on (not pressed) end caps. The axles are supported with individual cast housing bearings for the ultimate in strength and reliability.



Film tail cut & wipe

Simple, yet highly effective aptly describes the unique film tail treatment system on the FA-55. At the end of the wrapping cycle, Orion's innovative asymmetrical film clamp grips the film web while the pneumatic thermobar cuts the film. Then, Orion's load-seeking pneumatically actuated brush smooths and secures the film tail to the side of the load as it is conveyed to the exit conveyor. The result is an attractive, secure film tail that stays in place using a minimal amount of film.



The Insta-Thread film carriage has a hinged roller frame for film threading that's fast, safe and easy.

Insta-Thread™ Powered Prestretch System

- Uses standard 20" stretch film rolls
- Precision ground, polyurethane prestretch rollers for consistent, maximum film yield
- 245% standard pre-stretch ratio for economy
- Carriage lifted by heavy-duty ANSI industrial chain
- Electronic film tension control on control panel
- Variable speed film output (non-wearing sensor)
- Heavy-duty ANSI chain & sprocket ratio control
- Insta-Sense™ film out / break alarm light

Controller

- Free standing CSA Approved NEMA 12 rated control panel
- User-friendly, non-proprietary pushbuttons & switches
- Large mushroom-style Emergency E-Stop button
- Electronic film tension control on panel
- State-of-the-art Allen Bradley logic control for maximum flexibility
- Separate count settings for top wraps & bottom wraps
- Rewrap button for rewrapping after load replacement, E-stop, etc.
- End of cycle film force release
- Current overload protection



Orion Packaging Systems, Inc.
A Pro Mach Operating Partner
USA Corporate Headquarters
100 Crescent Drive
Collierville, TN 38017
Toll Free (800) 333-6556
Telephone (901) 888-4170
Fax (901) 365-1071
CANADA Manufacturing
2270 Industrial Blvd
Laval, Quebec, H7S 1P9
Telephone (450) 667-9769
Fax (450) 667-6320
Email: sales@orionpackaging.com
Web: www.orionpackaging.com
Bulletin #FA55.06/01.JKG

All dimensions approximate. Orion Packaging Systems reserves the right to change specifications without notice.